



# CAMILLA 100 TERRA COLLECTION

lavabi  
washbasins  
Waschbecken  
lavabo  
lavamano

 Cristallo  
crystal  
Kristallglas  
verre  
cristal

 top in marmo  
marble top  
Arbeitsplatte aus Marmor  
top en marbre  
top de mármol

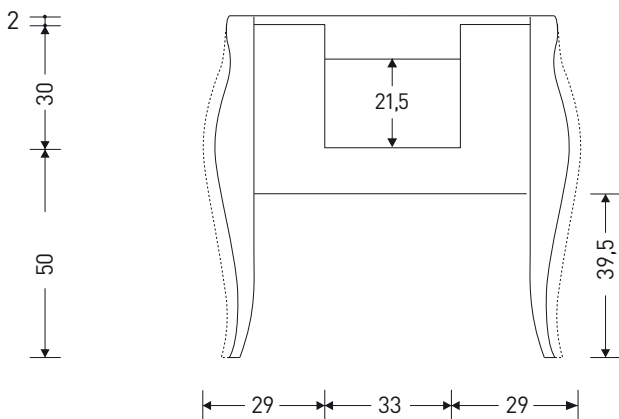
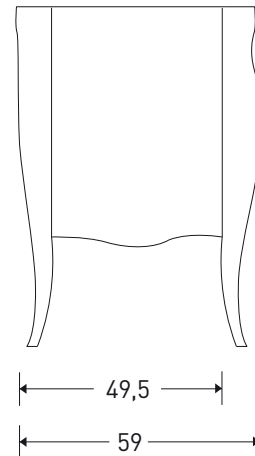
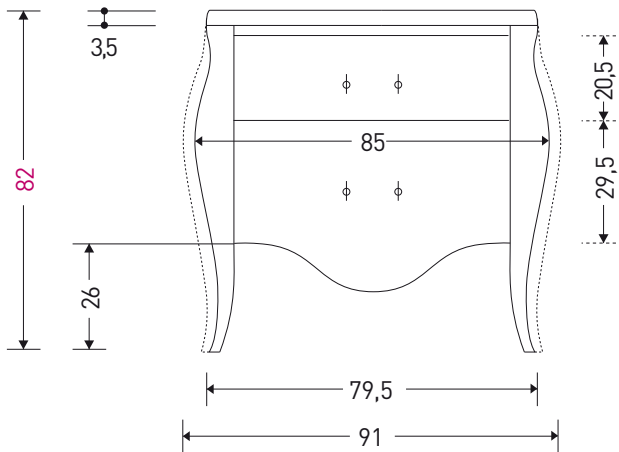
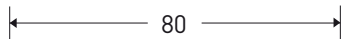
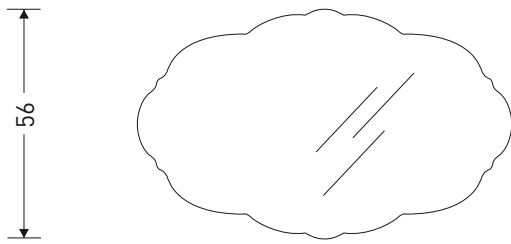

**EBAN s.r.l.**

Via Maestri Del Lavoro 28/30 - 62019 Recanati (MC) Tel +39 0717578025 - Fax +39 071987119  
e-mail: info@ebansrl.it - [www.ebansrl.it](http://www.ebansrl.it)